

ZapT-lok™



 **BarSplice**
PRODUCTS INC.
A SUBSIDIARY OF FC INDUSTRIES, INC.

HEADED REINFORCING BAR ANCHORAGE APPLICATIONS

HEADED BARS IN BEAM-COLUMN EXTERIOR JOINT

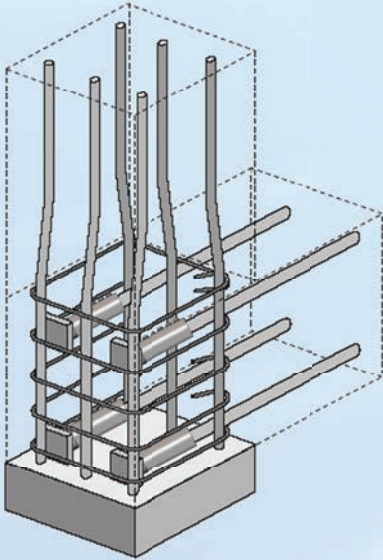

HEADED BARS IN BEAM-COLUMN KNEE JOINT

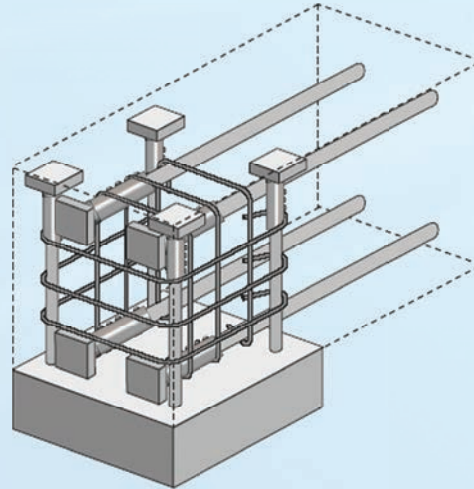

With the ZapT-lok™ Termination system, a head and short mechanical connector body with two converging sides are integrally manufactured for strength and compactness. A series of cone-pointed hex-head screws are arranged along the connector length. As the screws are tightened, they indent into the surface of the reinforcing bar, which in turn wedges into the converging sides of the connector. No special bar-end preparation is required, so ends can be sheared, sawed or flame-cut. Screws can be tightened using suitable impact wrenches. The heads of the screws shear-off at a prescribed tightening torque. ZapT-lok™ Termination heads are square with a net head bearing area equal to at least 9-times the nominal area of the reinforcing bar. Reinforcing bars that meet the deformation requirements of ASTM A615 / A615M or ASTM A706 / A706M can be anchored by this method.

There are many situations in which the amount of space available is not sufficient to fully develop or anchor straight reinforcing bars subjected to tension. In the past, the most commonly used technique to reduce the required development length of bars subjected to tension was to terminate the bars using a 90 deg or 180 deg hook. While hooks might be helpful in reducing development length, their use sometimes brings about congestion and other detailing problems. Sometimes, reinforcing bars can fracture prematurely at the hook region during or after fabrication. There are also times in which the reduction in development length is not large enough to satisfy the design constraints of a structural member. An alternative available to structural engineers, architects, and specifiers is the use of headed bar anchors to terminate reinforcing bars. ZapT-lok™ Terminations require shorter development lengths than straight bars and most hooked bars because most of the bond force is transmitted to the concrete directly through bearing of the termination head.

ZapT-lok™ Terminations can be used:

- to replace hooked reinforcing bars as mechanical anchors in applications such as beam-column joints, knee joints, pile caps or column roof slab connections
- to anchor reinforcing steel replacing stirrups or ties
- in deep beam applications
- to alleviate congestion in heavily reinforced concrete members, facilitating bar placement and concrete consolidation

As mechanical headed anchorage, ZapT-lok™ Terminations are alternatives to the embedment lengths of straight bars or hooks of deformed steel reinforcing bars in reinforced concrete specified in ACI 318 Sections 12.1.1 and 12.6 and UBC Sections 1912.1.1 and 1912.6, for development of reinforcing bars in tension. Related sections in the codes that permit or require mechanical anchorage of reinforcing bars are ACI 318 Sections 12.1.1, 12.10.6, 12.11.2, 12.11.3, 12.11.4 and 12.12.1; and UBC Sections 1912.1.1, 1912.10.6, 1912.11.2, 1912.11.3, 1912.11.4 and 1912.12.1.

While the information contained in this document is believed to be accurate at the time of publication, BPI reserves the right to make changes, design modifications, corrections and other revisions as it sees fit, without notice. All products described herein are supplied in accordance with BPI's standard Terms and Conditions of Sale. This document is of a promotional nature only. Aspects of structural design, evaluation of product fitness for use, suitability or similar attributes are the responsibility of others.



MEMBER

BarSplice Products, Inc., 4900 Webster Street, Dayton OH 45414, USA
● Tel: (937) 275-8700 ● Fax: (937) 275-9566 ● E-mail: bar@barsplice.com

Copyright © 2012, Barsplice Products, Inc., "BPI. All rights reserved.



MEMBER

REV.C 6/13/12